

# Chematic® 1



## Description

Chematic® 1 is a highly concentrated liquid cleaner ideally suited for CIP, COP, spray, and high pressure cleaning of processing equipment found in pharmaceutical, biopharmaceutical, cosmetics, and food facilities. A proprietary combination of chelating agents and surfactants enables Chematic® 1 to remove a wide variety of soils while remaining effective in hard water. Chematic® 1 is free rinsing and phosphate-free.

## Physical Properties

<b>Physical Form:</b>	Liquid
<b>Appearance:</b>	Colorless to light straw
<b>pH Use Solution: (1%-5% v/v):</b>	>11.0
<b>Specific Gravity at 68°F:</b>	1.09-1.13
<b>Foaming:</b>	Low foaming @ use temp
<b>Typical Storage Temperature:</b>	40°F – 100°F

**Substrate compatibility:** Product is safe on stainless steel, glass and many plastics and polymers. Product should be thoroughly rinsed off surfaces. Not recommended for soft metals.

**Precautionary Statement:** Please refer to the current Material Safety Data Sheet.

## Applications and Usage:

**CIP, COP & Spray Applications:**  
Concentrations from 1%-10% v/v  
Temperatures: 70°C-80°C

**Manual Application:**  
Concentrations from 0.5%-2% v/v  
Temperatures: 25°C-50°C

## Cleaning Validation Support:

HPLC, TOC, IMS and other methods are provided by the Dober Group. Validation consulting support ranging from complete project management to sampling and swabbing methodologies and assistance is available from our validation consulting group.



## Available in:

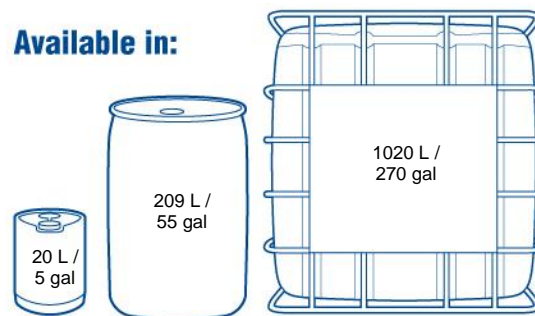

**DOBER**  
CLEANER WITH CHEMATIC®

### Dober Innovation & Technology Center

11230 Katherine's Crossing  
Woodridge, IL 60517  
Toll free +1-800-323-4983  
Local +1-630-410-7300  
www.dobergroup.com